

BSR Miniature Spectral Irradiance Meter



The BSR112E is a miniature Spectral Irradiance Meter designed for field, industrial, and lab applications with a plug-and-play USB 2.0 interface. Equipped with a cosine corrective lens this spectrometer is irradiance calibrated against a NIST traceable tungsten light source. Optimized software is provided for characterization and measurement of many application lighting devices and systems. Standard software features include time line recording, data smoothing, illuminance (lux), chromaticity, color temperature, external triggered pulsed light capturing, and other data handling functions. The spectral irradiance meter is ideal for lamp and LED characterization (requires different input optic options), and color analysis, solar studies, photostability testing, photobiology and photochemistry.

Highlights:

- Spectral range: 380-750 nm, 350-1050nm
- Spectral resolution: 2.8 - 3.9 nm
- Input optics: transmissive cosine receptor (default)
- CIE 127 compliant adaptor available (optional)
- Irradiance range: 100 nW/cm²/nm - 1 mW/cm²/nm (with 350-1050 nm version)
200 nW/cm²/nm - 2 mW/cm²/nm (with 380-750 nm version)
- NIST traceable calibration built-in
- Wavelength accuracy: better than 0.3 nm

Applications:

- Illumination and color rendering from lighting
- Solar irradiance monitoring (outdoors)
- Solar simulator validation (indoors)
- UV curing system QC
- LED Characterization

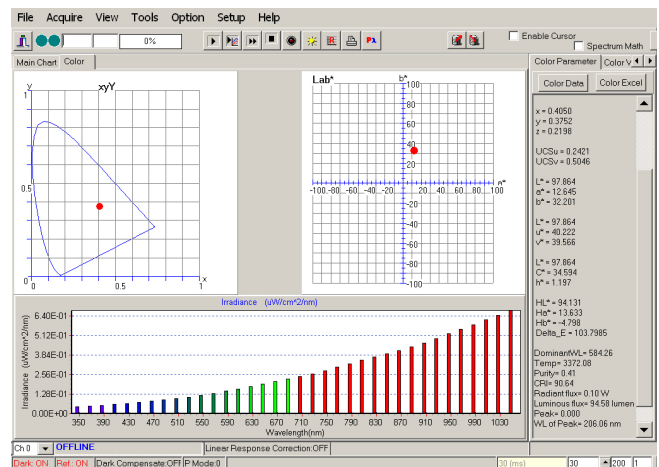
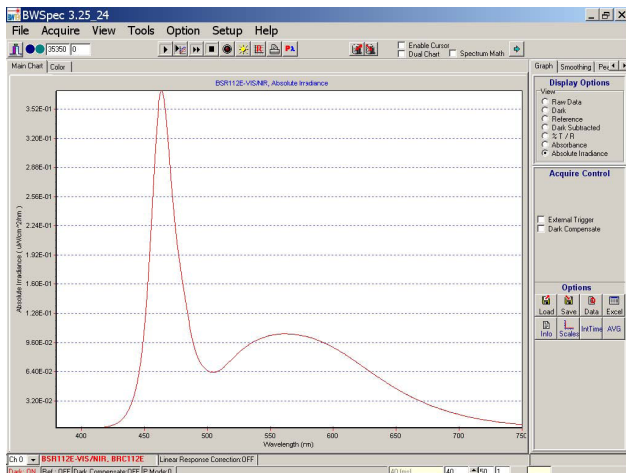

Specifications:

Power Input	USB at < 350mA
Detector Type	Response enhanced 2048 element linear silicon CCD array
Detector Pixel Format	2048 x 1 elements @ 14µm x 200µm per element
Spectrograph F#	3.0
Spectrograph Optical Layout	Crossed Czerny-Turner
Dynamic Range	275 typical
Digitizer Resolution	16-bit or 65,535:1
Readout Speed	500 kHz
Data Transfer Speed	Up to 180 spectra per second via USB 2.0
Effective Integration Time	1 - >=20,000 ms
External Trigger	Aux Port
Operating Temperature	15°C - 35°C
Relative Humidity	0 - 85% RH non condensing
Weight	~0.23 kg (0.5 lbs)
Dimensions	See Demension Drawings
Computer Interface	USB 2.0
Operating Systems	Windows 2000, XP, Vista (32 bit), & Windows 7 (32 bit)

Dimensions (mm):

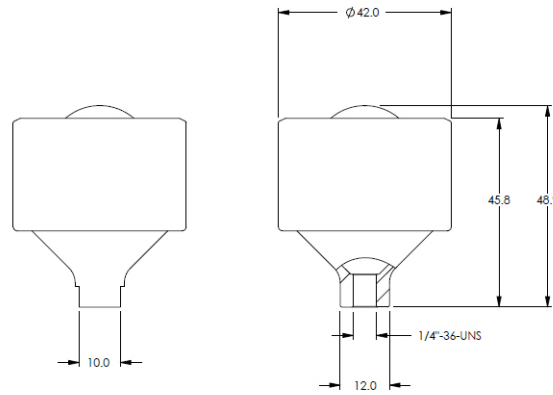

Dimensions (mm):

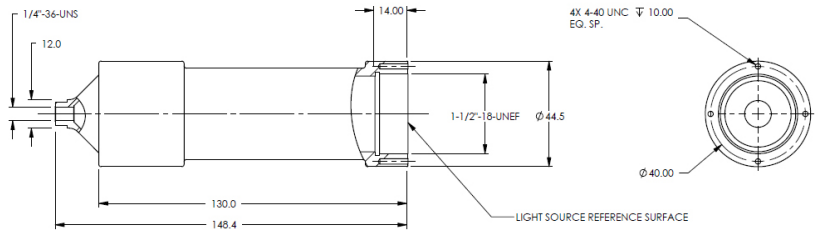

Dimensions (inches):

